

## 2.5 General motor data

General information		Cooling type A	
CE certification		Yes	
C-UR-US listed		Yes	
UL file number		PRHZ2.E235396	
Electrical characteristics			
DC bus voltage on the ACOPOSmicro		80VDC <sup>1)</sup>	
Conventional connection type (power connection / encoder connection)		ytec circular connector from Intercontec	
Connection type - Single-cable solution (hybrid)		htec circular connector from Intercontec	
Thermal characteristics			
Insulation class in accordance with EN 60034-1		F	
Methods of cooling in accordance with EN 60034-6 (IC code)		Self-cooling, no separate surface cooling (IC4A0A0)	
Thermal motor protection in accordance with EN 60034-11		Size 1: No, size 2 and 3: KTY 83-110 Maximum winding temperature 155°C (limited by the thermal motor protection in the ACOPOSmicro drive system to 110°C with EnDat feedback and 130°C with resolver feedback)	
Mechanical characteristics			
Roller bearing, dynamic load ratings and nominal service life		Based on DIN ISO 281	
Shaft end in accordance with DIN 748		Form E	
Oil seal in accordance with DIN 3760		Form A	
Key and keyway in accordance with DIN 6885-1		Form A keys, form N1 keyway	
Balancing the shaft in accordance with ISO 1940/1, G6.3		Half-key arrangement	
Mounting flange		IEC 72-1	
Smooth rotation of shaft end, coaxial properties and mounting flange plane in accordance with DIN 42955		Tolerance R	
Coating		Water-based coating	
Color		RAL 9005 flat	
Operating conditions			
Rating class, operating mode in accordance with EN 60034-1		S1 - Continuous operation	
Ambient temperature during operation		-15°C to +40°C	
Maximum ambient temperature during operation		+50°C <sup>2)</sup>	
Relative humidity during operation		5 to 95%, non-condensing	
Reduction of the nominal current and stall current at temperatures above 40°C		5% per 5°C	
Reduction of the nominal current and stall current at installation elevations starting at 1000 m above sea level		10% per 1000 m	
Maximum installation elevation		2000 m <sup>3)</sup>	
Max. flange temperature		65°C	
EN 60034-5 protection (IP code)		IP54 <sup>4)</sup>	
With optional oil seal		IP65 <sup>4) 5)</sup>	
Construction and mounting arrangement type in accordance with EN 60034-7 (IM code)		Horizontal (IM3001) Vertical, motor hangs on the machine (IM3011) Vertical, motor stands on the machine (IM3031)	
Storage and transport conditions			
Storage temperature		-20 to +60°C	
Relative humidity during storage		Max. 90%, non-condensing	
Transport temperature		-20 to +60°C	
Relative humidity during transport		Max. 90%, non-condensing	

<sup>1)</sup> Permitted DC bus voltage on the ACOPOS single-phase: 320 VDC

<sup>2)</sup> Continuous operation at ambient temperatures ranging from +40°C to max. +50°C is possible, but this will result in a shorter service life.

<sup>3)</sup> Requirements that go beyond this must be arranged with B&R.

<sup>4)</sup> The protection ratings are only achieved if the power and signal connections are installed properly.

<sup>5)</sup> The protection ratings are only achieved if the power and signal connections are installed properly.

<sup>5)</sup> Only available for size 2 and 3!

## 2.11 8LVA3 - Technical data

### Size 3

Model number	8LVA33.ee005ffe0	8LVA33.ee015ffgg-0	8LVA33.ee021ffgg-0
<b>Motor</b>			
Nominal speed $n_N$ [rpm]	500	1500	2100
Number of pole pairs		4	
Nominal torque $M_n$ [Nm]	2.4	2.5	2.45
Nominal power $P_N$ [W]	126	393	539
Nominal current $I_N$ [A]	2	6	7.3
Stall torque $M_0$ [Nm]		2.6	
Stall current $I_0$ [A]	2.2	6.3	7.9
Maximum torque $M_{max}$ [Nm]		7.2	
Maximum current $I_{max}$ [A]	7.6	20.4	26
Maximum speed $n_{max}$ [rpm]		6600	
Torque constant $K_T$ [Nm/A]	1.18	0.42	0.33
Voltage constant $K_E$ [V/1000 rpm]	71.21	25.13	19.9
Stator resistance $R_{2ph}$ [ $\Omega$ ]	6.24	0.808	0.503
Stator inductance $L_{2ph}$ [mH]	24.12	3.3	2
Electrical time constant $t_{el}$ [ms]	3.9	4.1	4
Thermal time constant $t_{therm}$ [min]		34	
Moment of inertia $J$ [kgcm <sup>2</sup> ]		0.95	
Mass without brake $m$ [kg]		2.45	
<b>Holding brake</b>			
Holding torque of the brake $M_{Br}$ [Nm]	2.2		3.2
Brake mass [kg]		0.57	
Moment of inertia for the brake $J_{Br}$ [kgcm <sup>2</sup> ]	0.12		0.38
<b>Recommendations</b>			
ACOPOS 8Vxxxx.xx...	1016.50		1090
ACOPOS P3 8EI...	4X5M		8X8M
ACOPOSmicro 80VD100Px.xxxx-01		C0XX	
Cross section for B&R motor cables [mm <sup>2</sup> ]		0.75	
Connector size		1.0	

**Servo drive:** The recommended servo drive / inverter module is designed for 1.1x the stall current. If more than double the amount is needed during the acceleration phase, the next larger servo drive should be selected. This recommendation is only a guideline; detailed inspection of the corresponding speed/torque characteristic curve can result in deviations of the servo drive size (larger or smaller).

**ACOPOS missing information:** The DC bus voltage must be reduced in order to operate this device with an ACOPOS drive (max. 325 VDC).

**ACOPOSmulti:** Operating this device with ACOPOSmulti inverter module is not possible due to the high DC bus voltage when powered from the mains.

**NOTE cable:** The suitable cables can be found in the catalog (Book 1) chapter ACOPOSmicro servo drive.

### 2.11.1 8LVA33 - Dimensions

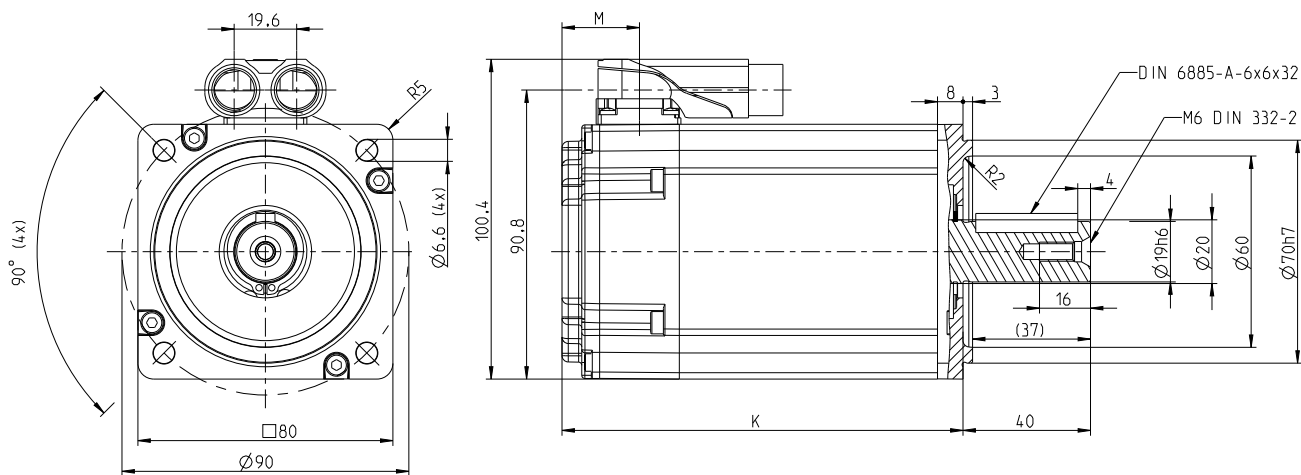

Double angular built-in connector

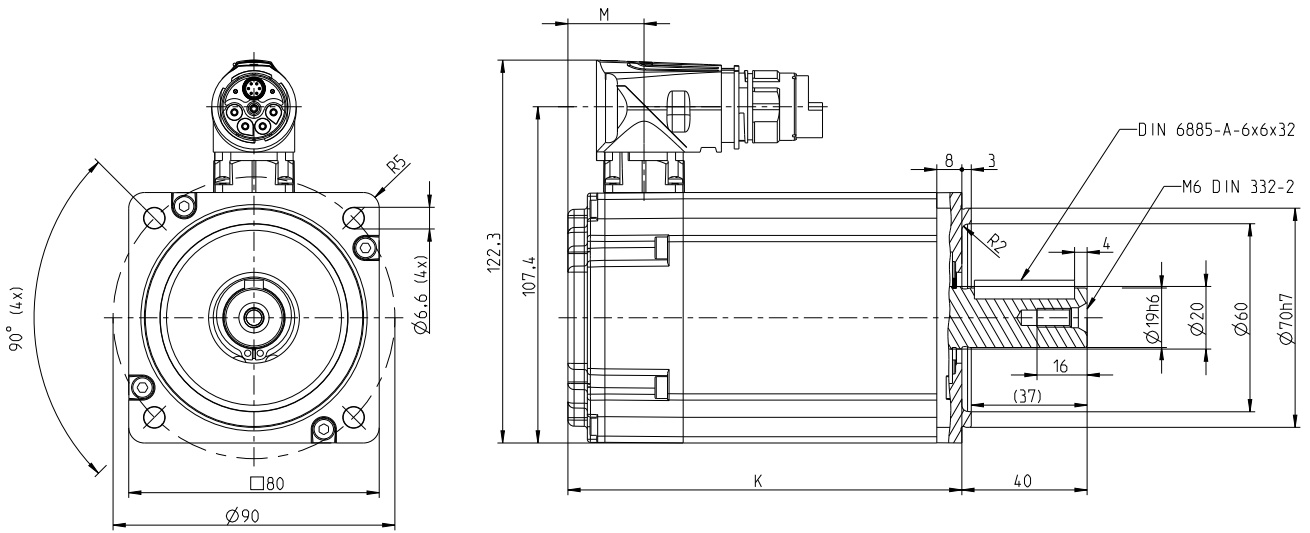

Single-cable solution

EnDat/Resolver feedback					Extension of K depending on motor option	
Model number	K	K	M	M	Holding brake	Oil seal
Encoder assignments	R0, B1	B8, B9	R0, B1	B8, B9		
8LVA33	119	126	17.5	24.5	36	5

IMPORTANT: Dimensions K and M depend on the length of the encoder cover.

### 2.11.2 Maximum shaft load

The values in the diagram below are based on a mechanical service life of the bearings of 20,000 operating hours.

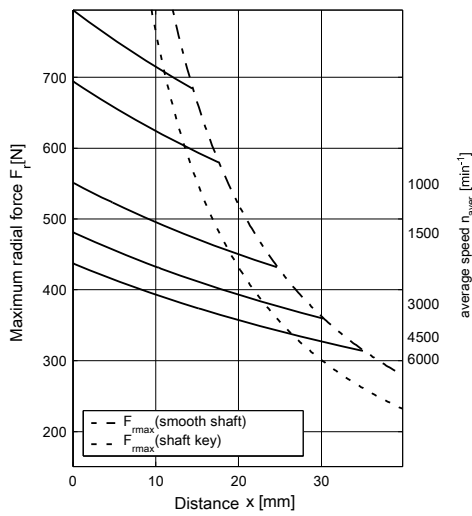

maximum allowed axial force:  $F_{amax} = 75 \text{ N}$

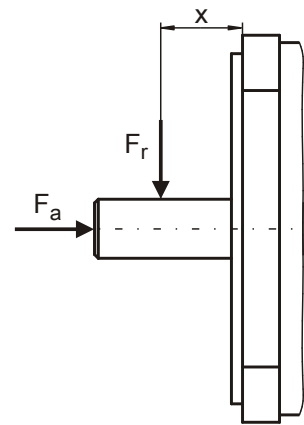
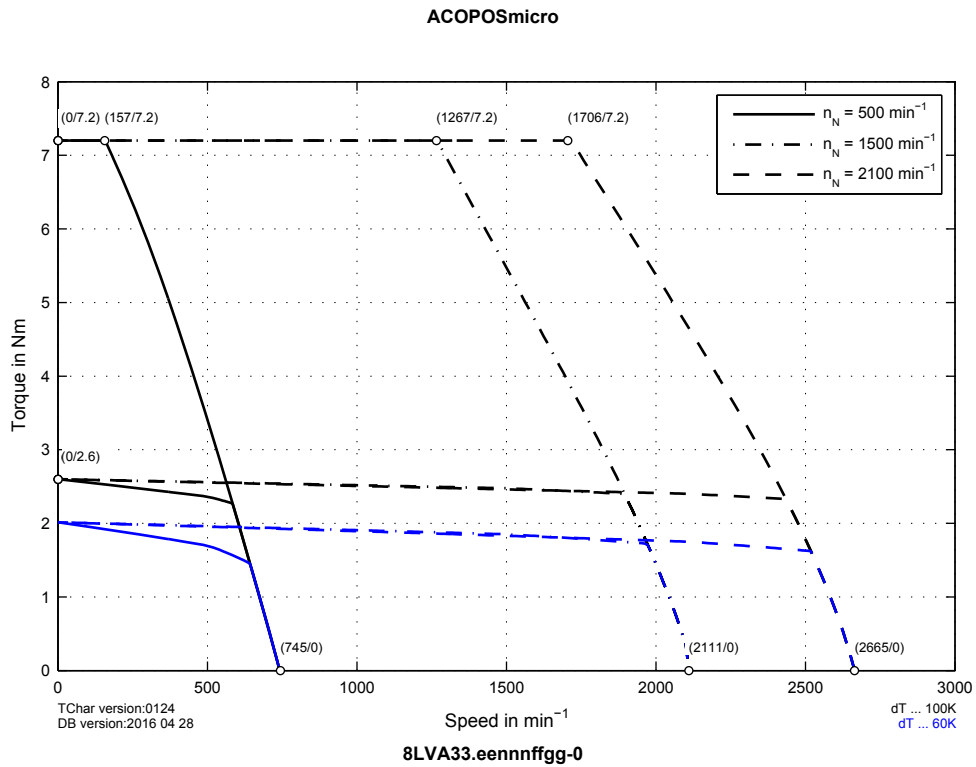

Figure 3: Definition of shaft load

- $F_r$ ..... Radial force
- $F_a$ ..... Axial force
- $x$ ..... Distance between the motor flange and the point where radial force  $F_r$  is applied

### 2.11.3 Speed-Torque characteristic curve at 80 VDC DC bus voltage



### 2.11.4 Speed-Torque characteristic curve at 325 VDC DC bus voltage

