



DE Anbauanleitung
8GF60

GB Mounting instructions
8GF60

FR Instructions de montage
8GF60

IT Istruzioni di montaggio
8GF60

ES Instrucciones montaje
8GF60

Datum:	19.07.2018
Seite:	1/1
Version:	1.1

ISO-Dokument

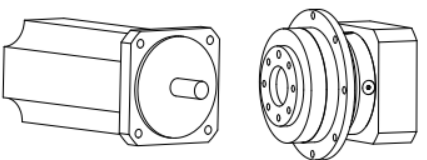
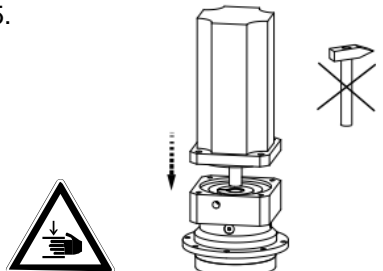
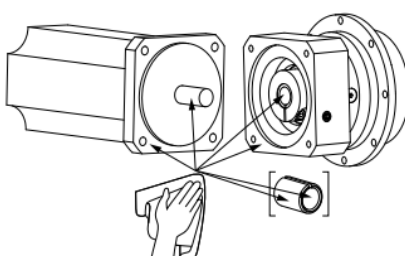
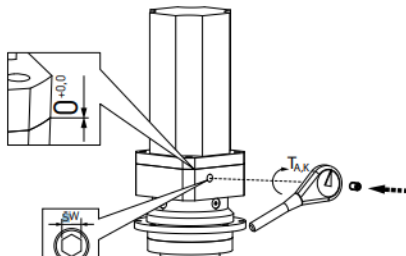
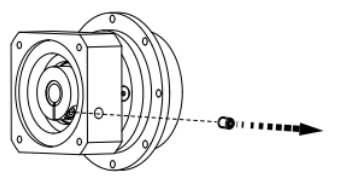
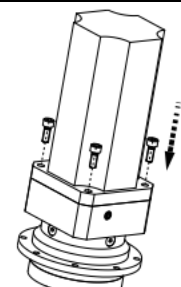
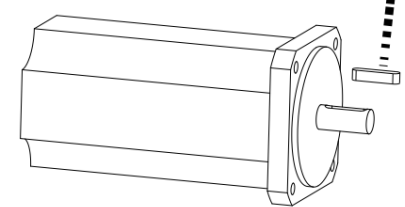
<p>1.</p> 	<p>DE DIN 42955-N richtiger Motor? Richtiges Getriebe?</p> <p>GB DIN 42955-N right motor? Right gearbox?</p> <p>FR DIN 42955-N moteur adapté ? Réducteur adapté ?</p> <p>IT DIN 42955-N motore corretto? Riduttore corretto?</p> <p>ES DIN 42955-N motor correcto? Reductor correcto?</p>	<p>5.</p> 	<p>DE Klemmschraube öffnen, $d_{Motor} < d_{Hohlwelle}$: Buchse verwenden, Motormontage bevorzugt in vertikaler Position, Motor in Getriebe fügen</p> <p>GB Open clamping screw, $d_{motor} < d_{hollow\ shaft}$: use bushing, motor mounting preferred in vertical position, fit the motor in the gear</p> <p>FR Dévisser la vis de serrage, $d_{moteur} < d_{arbre\ creux}$: utiliser une douille, monter le moteur de préférence en position verticale, insérer le moteur dans le réducteur</p> <p>IT Aprire la vite di bloccaggio, $d_{motore} < d_{albero\ cavo}$: utilizzare la boccia, montaggio motore preferibile in posizione verticale; accoppiare il motore al riduttore</p> <p>ES Abrir el tornillo de sujeción, $d_{motor} < d_{eje\ hueco}$: Utilizar un casquillo, efectuar el montaje del motor preferentemente en posición vertical, insertar el motor en el reductor</p>																																												
<p>2.</p> 	<p>DE Fettfrei reinigen, eventuelle Beschädigungen entfernen</p> <p>GB Clean grease free, rectify any damages</p> <p>FR Dégraisser, éliminer les endommagements éventuels</p> <p>IT Sgrassare, rimuovere eventuali danneggiamenti</p> <p>ES Limpiar de grasa, eliminar cualquier posible daño</p>	<p>6.</p> 	<p>DE Motorflansch muss an Getriebeflansch anliegen, Klemmung mit T_{AK} anziehen, Abdeckschraube einschrauben</p> <p>GB Motor flange adjacent on gear flange, tighten clamping ring with T_{AK}</p> <p>FR Le flasque du moteur doit adhérer au flasque du réducteur; serrer la bague de serrage avec T_{AK} visser la vis de protection</p> <p>IT La flangia motore deve essere a contatto con la flangia riduttore, Serrare l'anello di bloccaggio a T_{AK} avvitare la vite di copertura</p> <p>ES La brida del motor tiene que descansar sobre la brida del reductor; apretar la junta de unión con T_{AK} atornillar el tapón roscado</p>																																												
<p>3.</p> 	<p>DE Abdeckschraube entfernen, Stellung der Klemmschraube justieren</p> <p>GB Remove cover screw, adjust position of clamping screw</p> <p>FR Déposer la vis de protection, ajuster la position de la vis de serrage</p> <p>IT Rimuovere la vite di copertura, regolare la posizione della vite di bloccaggio</p> <p>ES Quitar el tapón roscado, ajustar la posición del tornillo de sujeción</p>	<p>7.</p> 	<p>DE Schrauben mit der Festigkeitsklasse 8.8 verwenden, Schrauben müssen gesichert werden; Anzugsmoment (T_{AS}) der Schraube: 90% der Schraubenstreckgrenze nutzen, Schrauben mit T_{AS} und über Kreuz anziehen</p> <p>GB use screws with the property class 8.8, screws must be secured, tightening torque (T_{AS}) of the screw: use 90% of screws yield stress, tighten screws with T_{AS}, screws tighten crosswise</p> <p>FR Utiliser des vis à Classe de qualité de 8.8, les vis doivent être bloquées ; couple de serrage (T_{AS}) des vis : utiliser 90% de la limite d'élasticité des vis, serrer les vis avec T_{AS} en croix</p> <p>IT Utilizzare viti con una classe di resistenza minima di 8.8; fissare le viti; coppia di serraggio (T_{AS}) della vite: utilizzare il 90% del limite di elasticità, serrare le viti a T_{AS} e in sequenza incrociata</p> <p>ES emplear tornillos con una Clase de resistencia de 8.8; hay que fijar los tornillos; par de apriete (T_{AS}) de los tornillos: emplear un 90% del límite de elasticidad; apretar los tornillos con T_{AS} y hacerlo en cruz</p>																																												
<p>4.</p> 	<p>DE Bei Motor mit Passfeder muss diese entfernt werden</p> <p>GB If the motor has a feather key, remove it</p> <p>FR Déposer celle-ci sur les moteurs à clavette</p> <p>IT In caso di motore con chiavetta, rimuoverla</p> <p>ES En caso de motor con claveta, hay que quitar ésta</p>	<table border="1"> <thead> <tr> <th>Getriebe / Gearbox / Réducteur / Riduttore / Reductor</th> <th colspan="2">8GF60-064</th> <th colspan="2">8GF60-090</th> <th colspan="3">8GF60-110</th> <th colspan="3">8GF60-140</th> <th colspan="2">8GF60-200</th> </tr> <tr> <td>T_{AK} [Nm]</td> <td>4,5</td> <td>9,5</td> <td>4,5</td> <td>9,5</td> <td>16,5</td> <td>9,5</td> <td>16,5</td> <td>40</td> <td>16,5</td> <td>40</td> <td>75</td> <td>40</td> <td>75</td> </tr> <tr> <td>SW* [mm]</td> <td>3</td> <td>4</td> <td>3</td> <td>4</td> <td>5</td> <td>4</td> <td>5</td> <td>6</td> <td>5</td> <td>6</td> <td>8</td> <td>6</td> <td>8</td> </tr> </thead> </table> <p>*Schlüsselweite für Innensechskant Wrench width for allen key</p>					Getriebe / Gearbox / Réducteur / Riduttore / Reductor	8GF60-064		8GF60-090		8GF60-110			8GF60-140			8GF60-200		T_{AK} [Nm]	4,5	9,5	4,5	9,5	16,5	9,5	16,5	40	16,5	40	75	40	75	SW* [mm]	3	4	3	4	5	4	5	6	5	6	8	6	8
Getriebe / Gearbox / Réducteur / Riduttore / Reductor	8GF60-064		8GF60-090		8GF60-110			8GF60-140			8GF60-200																																				
T_{AK} [Nm]	4,5	9,5	4,5	9,5	16,5	9,5	16,5	40	16,5	40	75	40	75																																		
SW* [mm]	3	4	3	4	5	4	5	6	5	6	8	6	8																																		