

# X20(c)AI4622

## 1 General information

The module is equipped with 4 inputs with 13-bit (including sign) digital converter resolution. It is possible to select between the current and voltage signal using different terminals.

- 4 analog inputs
- Either current or voltage signal possible
- 13-bit digital converter resolution

## 2 Coated modules

Coated modules are X20 modules with a protective coating for the electronics component. This coating protects X20c modules from condensation and corrosive gases.

The modules' electronics are fully compatible with the corresponding X20 modules.

**For simplification purposes, only images and module IDs of uncoated modules are used in this data sheet.**

The coating has been certified according to the following standards:

- Condensation: BMW GS 95011-4, 2x 1 cycle
- Corrosive gas: EN 60068-2-60, method 4, exposure 21 days



### 2.1 -40°C starting temperature

The starting temperature describes the minimum permissible ambient temperature when the power is switched off at the time the coated module is switched on. This is permitted to be as low as -40°C. During operation, the conditions as specified in the technical data continue to apply.

#### Information:

**It is important to absolutely ensure that there is no forced cooling by air currents in a closed control cabinet, for example using a fan or ventilation slots.**

## 3 Order data

Model number	Short description	Figure
X20AI4622	<b>Analog inputs</b> X20 analog input module, 4 inputs, $\pm 10$ V or 0 to 20 mA / 4 to 20 mA, 13-bit converter resolution, configurable input filter	
X20cAI4622	X20 analog input module, coated, 4 inputs, $\pm 10$ V or 0 to 20 mA / 4 to 20 mA, 13-bit converter resolution, configurable input filter	
	<b>Required accessories</b>	
	<b>Bus modules</b>	
X20BM11	X20 bus module, 24 VDC keyed, internal I/O supply continuous	
X20BM15	X20 bus module, with node number switch, 24 VDC keyed, internal I/O supply continuous	
X20cBM11	X20 bus module, coated, 24 VDC keyed, internal I/O supply continuous	
	<b>Terminal blocks</b>	
X20TB12	X20 terminal block, 12-pin, 24 VDC keyed	

Table 1: X20AI4622, X20cAI4622 - Order data

## 4 Technical data

Model number	X20AI4622	X20cAI4622
<b>Short description</b>		
I/O module	4 analog inputs $\pm 10$ V or 0 to 20 mA / 4 to 20 mA	
<b>General information</b>		
B&R ID code	0x1BAA	0xE1EF
Status indicators	I/O function per channel, operating state, module status	
Diagnostics		
Module run/error	Yes, using status LED and software	
Inputs	Yes, using status LED and software	
Channel type	Yes, using software	
Power consumption		
Bus	0.01 W	
Internal I/O	1.1 W <sup>1)</sup>	
Additional power dissipation caused by actuators (resistive) [W]	-	
Certifications		
CE	Yes	
ATEX	Zone 2, II 3G Ex nA nC IIA T5 Gc IP20, Ta (see X20 user's manual) FTZU 09 ATEX 0083X	
UL	cULus E115267 Industrial control equipment	
HazLoc	cCSAus 244665 Process control equipment for hazardous locations Class I, Division 2, Groups ABCD, T5	
DNV GL	Temperature: <b>B</b> (0 - 55°C) Humidity: <b>B</b> (up to 100%) Vibration: <b>B</b> (4 g) EMC: <b>B</b> (bridge and open deck)	
KR	Yes	
EAC	Yes	
KC	Yes	-
<b>Analog inputs</b>		
Input	$\pm 10$ V or 0 to 20 mA / 4 to 20 mA, via different terminal connections	
Input type	Differential input	
Digital converter resolution		
Voltage	$\pm 12$ -bit	
Current	12-bit	
Conversion time	400 $\mu$ s for all inputs	
Output format	INT	
Output format		
Voltage	INT 0x8001 - 0x7FFF / 1 LSB = 0x0008 = 2.441 mV	
Current	INT 0x0000 - 0x7FFF / 1 LSB = 0x0008 = 4.883 $\mu$ A	
Input impedance in signal range		
Voltage	20 M $\Omega$	
Current	-	
Load		
Voltage	-	
Current	<400 $\Omega$	
Input protection	Protection against wiring with supply voltage	
Permissible input signal		
Voltage	Max. $\pm 30$ V	
Current	Max. $\pm 50$ mA	
Output of digital value during overload	Configurable	
Conversion procedure	SAR	
Input filter	3rd-order low pass / cutoff frequency 1 kHz	
Max. error		
Voltage		
Gain	0.08% <sup>2)</sup>	
Offset	0.015% <sup>3)</sup>	
Current		
Gain	0 to 20 mA = 0.08 % / 4 to 20 mA = 0.1 % <sup>2)</sup>	
Offset	0 to 20 mA = 0.03 % / 4 to 20 mA = 0.16 % <sup>4)</sup>	
Max. gain drift		
Voltage		
Voltage	0.006 %/°C <sup>2)</sup>	
Current	0 to 20 mA = 0.009 %/°C 4 to 20 mA = 0.0113 %/°C <sup>2)</sup>	
Max. offset drift		
Voltage		
Voltage	0.002 %/°C <sup>3)</sup>	
Current	0 to 20 mA = 0.004 %/°C 4 to 20 mA = 0.005 %/°C <sup>4)</sup>	

Table 2: X20AI4622, X20cAI4622 - Technical data

Model number	X20AI4622	X20cAI4622
Common-mode rejection		
DC		70 dB
50 Hz		70 dB
Common-mode range		±12 V
Crosstalk between channels		<-70 dB
Nonlinearity		
Voltage		<0.025% <sup>3)</sup>
Current		<0.05% <sup>4)</sup>
Isolation voltage between channel and bus		500 V <sub>eff</sub>
<b>Electrical properties</b>		
Electrical isolation		Channel isolated from bus Channel not isolated from channel
<b>Operating conditions</b>		
Mounting orientation		
Horizontal		Yes
Vertical		Yes
Installation elevation above sea level		
0 to 2000 m		No limitations
>2000 m		Reduction of ambient temperature by 0.5°C per 100 m
Degree of protection per EN 60529		IP20
<b>Ambient conditions</b>		
Temperature		
Operation		
Horizontal mounting orientation		-25 to 60°C
Vertical mounting orientation		-25 to 50°C
Derating		-
Storage		-40 to 85°C
Transport		-40 to 85°C
Relative humidity		
Operation	5 to 95%, non-condensing	Up to 100%, condensing
Storage		5 to 95%, non-condensing
Transport		5 to 95%, non-condensing
<b>Mechanical properties</b>		
Note	Order 1x X20TB12 terminal block separately Order 1x X20BM11 bus module separately	Order 1x X20TB12 terminal block separately Order 1x X20cBM11 bus module separately
Pitch	12.5 <sup>+0.2</sup> mm	12.5 <sup>+0.2</sup> mm

Table 2: X20AI4622, X20cAI4622 - Technical data

- 1) To reduce power dissipation, B&R recommends bridging unused inputs on the terminals or configuring them as current signals.
- 2) Based on the current measured value.
- 3) Based on the 20 V measurement range.
- 4) Based on the 20 mA measurement range.

## 5 LED status indicators

For a description of the various operating modes, see section "Additional information - Diagnostic LEDs" of the X20 system user's manual.

Figure	LED	Color	Status	Description
	r	Green	Off	No power to module
			Single flash	RESET mode
			Blinking	PREOPERATIONAL mode
			On	RUN mode
	e	Red	Off	No power to module or everything OK
			On	Error or reset status
	e + r		Red on / Green single flash	Invalid firmware
	1 - 4	Green	Off	Open line <sup>1)</sup> or sensor is disconnected
			Blinking	Input signal overflow or underflow
			On	Analog/digital converter running, value OK

- 1) Open line detection only possible when measuring voltage.

## 6 Pinout

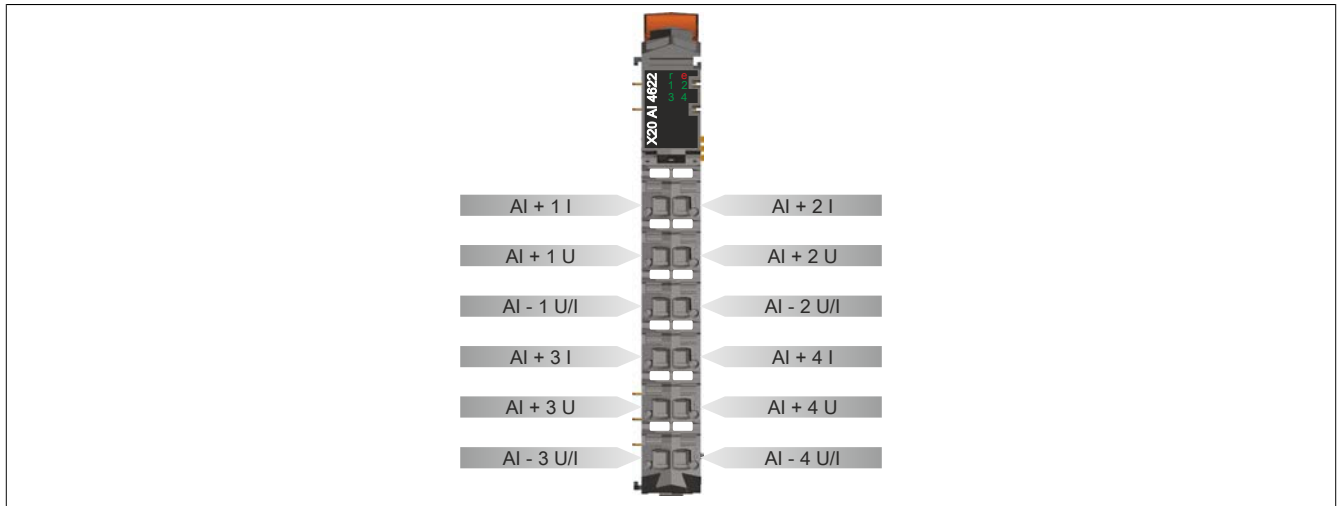

## 7 Connection example

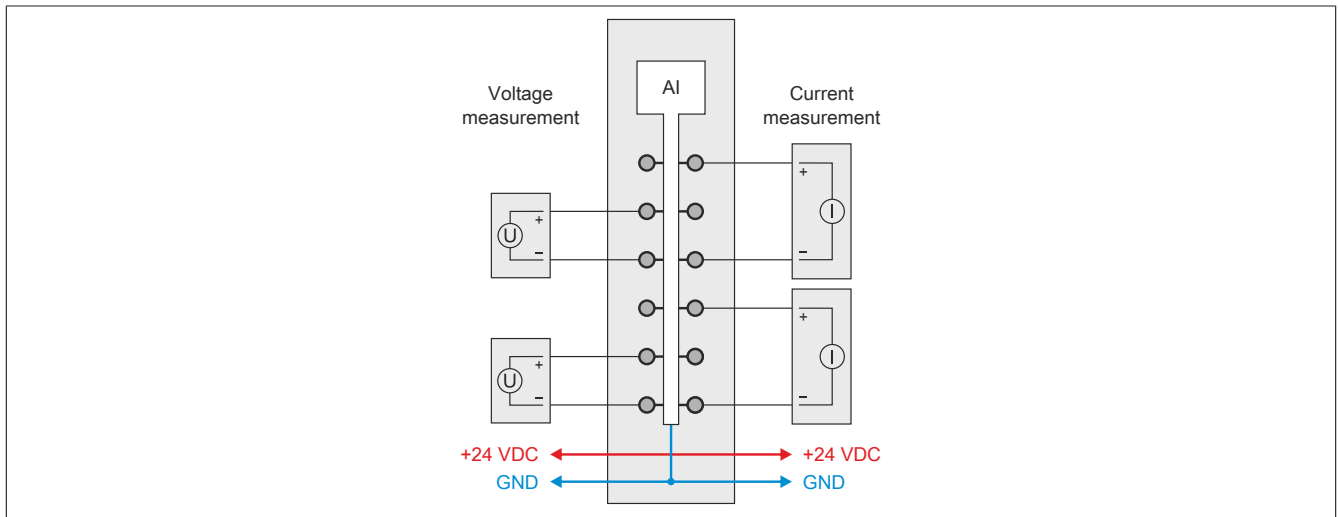

## 8 Input circuit diagram

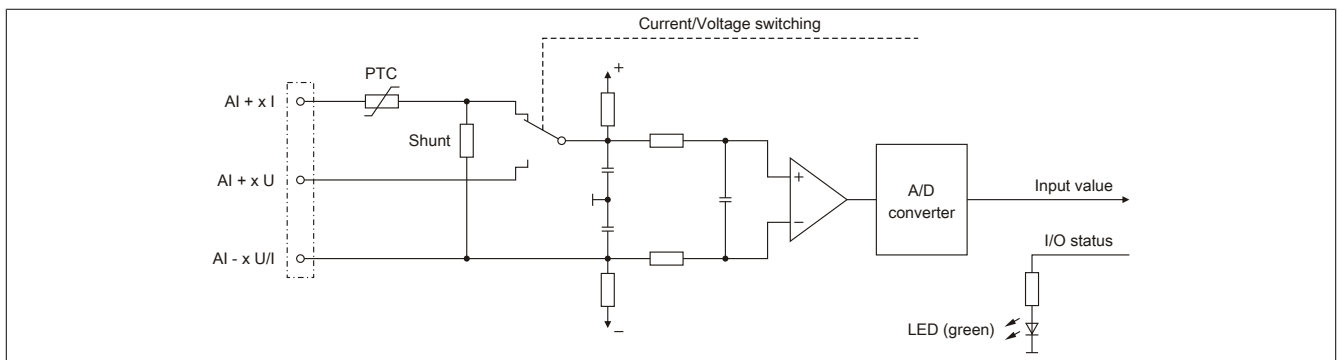

## 9 Register description

### 9.1 General data points

In addition to the registers described in the register description, the module has additional general data points. These are not module-specific but contain general information such as serial number and hardware variant.

General data points are described in section "Additional information - General data points" of the X20 system user's manual.

### 9.2 Function model 0 - Standard

Register	Name	Data type	Read		Write	
			Cyclic	Acyclic	Cyclic	Acyclic
<b>Configuration</b>						
16	ConfigOutput01 (input filter)	USINT				•
18	ConfigOutput02 (channel type)	USINT				•
20	ConfigOutput03 (lower limit value)	INT				•
22	ConfigOutput04 (upper limit value)	INT				•
<b>Communication</b>						
0	AnalogInput01	INT	•			
2	AnalogInput02	INT	•			
4	AnalogInput03	INT	•			
6	AnalogInput04	INT	•			
30	StatusInput01	USINT	•			

### 9.3 Function model 254 - Bus controller

Register	Offset <sup>1)</sup>	Name	Data type	Read		Write	
				Cyclic	Acyclic	Cyclic	Acyclic
<b>Configuration</b>							
16	-	ConfigOutput01 (input filter)	USINT				•
18	-	ConfigOutput02 (channel type)	USINT				•
20	-	ConfigOutput03 (lower limit value)	INT				•
22	-	ConfigOutput04 (upper limit value)	INT				•
<b>Communication</b>							
0	0	AnalogInput01	INT	•			
2	2	AnalogInput02	INT	•			
4	4	AnalogInput03	INT	•			
6	6	AnalogInput04	INT	•			
30	-	StatusInput01	USINT		•		

1) The offset specifies the position of the register within the CAN object.

#### 9.3.1 Using the module on the bus controller

Function model 254 "Bus controller" is used by default only by non-configurable bus controllers. All other bus controllers can use other registers and functions depending on the fieldbus used.

For detailed information, see section "Additional information - Using I/O modules on the bus controller" of the X20 user's manual (version 3.50 or later).

#### 9.3.2 CAN I/O bus controller

The module occupies 1 analog logical slot on CAN I/O.

### 9.4 Analog inputs

The input state is collected with a fixed offset to the network cycle and transferred in the same cycle.

### 9.5 Input values of analog inputs

Name:

AnalogInput01 to AnalogInput04

This register contains the analog input value depending on the configured operating mode.

Data type	Values	Input signal:
INT	-32768 to 32767	Voltage signal -10 to 10 VDC
	0 to 32767	Current signal 0 to 20 mA
	-8192 to 32767	Current signal 4 to 20 mA (value 0 corresponds to 4 mA)

## 9.6 Input filter

This module is equipped with a configurable input filter. The minimum X2X cycle time must be  $>500 \mu\text{s}$ . Filtering is disabled for shorter X2X cycle times.

If the input filter is active, then the channels are scanned in 1 ms cycles. The time offset between the channels is 200  $\mu\text{s}$ . Conversion is performed acyclically to the X2X cycle.

### Information:

The filter sampling time is fixed at 1 ms and is acyclic to the X2X cycle.

#### 9.6.1 Input ramp limiting

Input ramp limiting can only be performed in conjunction with filtering. Input ramp limiting is performed before filtering.

The difference of the input value change is checked for exceeding the specified limit. In the event of overshoot, the tracked input value is equal to the old value  $\pm$  the limit value.

Configurable limit values:

Value	Limit value
0	The input value is used without limitation.
1	0x3FFF = 16383
2	0x1FFF = 8191
3	0x0FFF = 4095
4	0x07FF = 2047
5	0x03FF = 1023
6	0x01FF = 511
7	0x00FF = 255

Input ramp limiting is well suited for suppressing disturbances (spikes). The following examples show the functionality of input ramp limiting based on an input step and a disturbance.

#### Example 1

The input value jumps from 8000 to 17000. The diagram shows the tracked input value with the following settings:

Input ramp limiting = 4 = 0x07FF = 2047

Filter level = 2

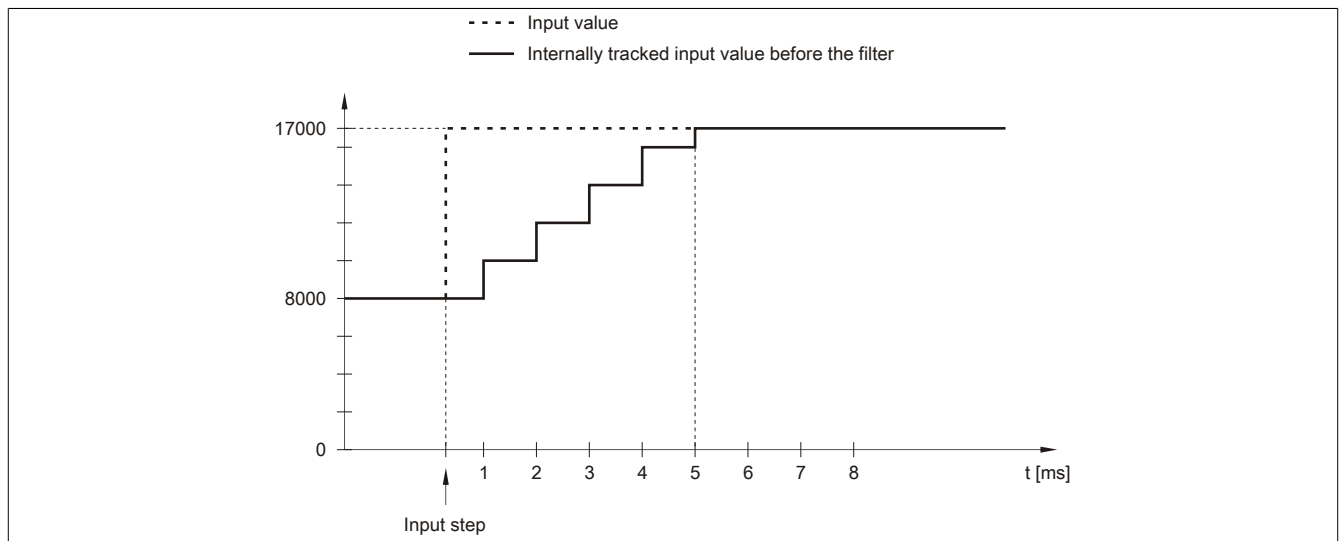

Figure 1: Tracked input value for input step

**Example 2**

A disturbance interferes with the input value. The diagram shows the tracked input value with the following settings:

Input ramp limiting = 4 = 0x07FF = 2047

Filter level = 2

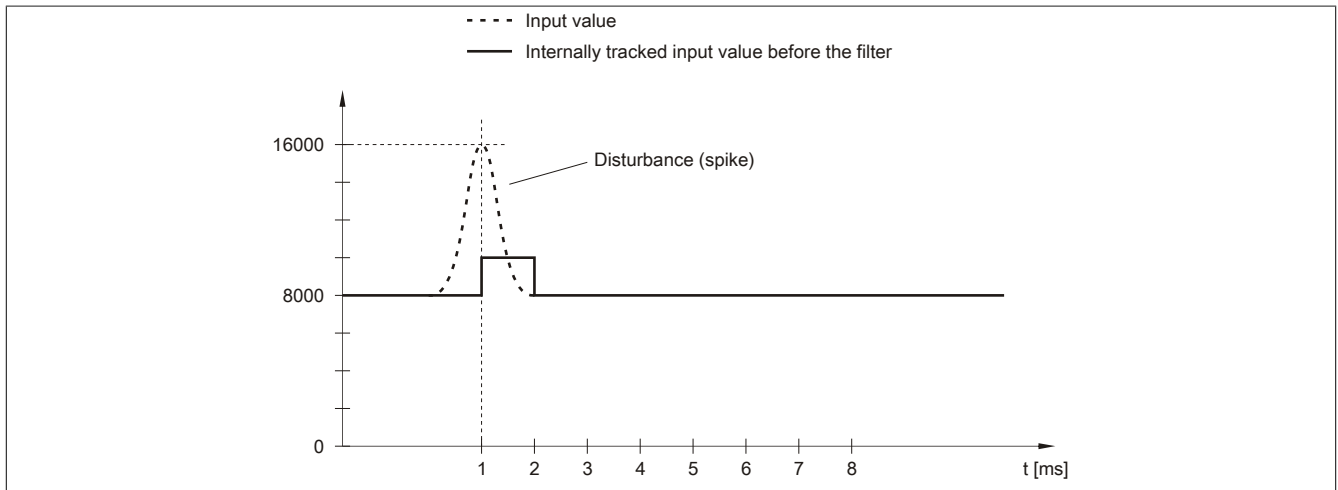

Figure 2: Tracked input value for disturbance

**9.6.2 Filter level**

A filter can be defined to prevent large input steps. This filter is used to bring the input value closer to the actual analog value over a period of several milliseconds.

Filtering takes place after any input ramp limiting has been carried out.

Formula for calculating the input value:

$$\text{Value}_{\text{New}} = \text{Value}_{\text{Old}} - \frac{\text{Value}_{\text{Old}}}{\text{Filter level}} + \frac{\text{Input value}}{\text{Filter level}}$$

Adjustable filter levels:

Value	Filter level
0	Filter switched off
1	Filter level 2
2	Filter level 4
3	Filter level 8
4	Filter level 16
5	Filter level 32
6	Filter level 64
7	Filter level 128

The following examples show the functionality of the filter based on an input step and a disturbance.

### Example 1

The input value jumps from 8000 to 16000. The diagram shows the calculated value with the following settings:

Input ramp limiting = 0

Filter level = 2 or 4

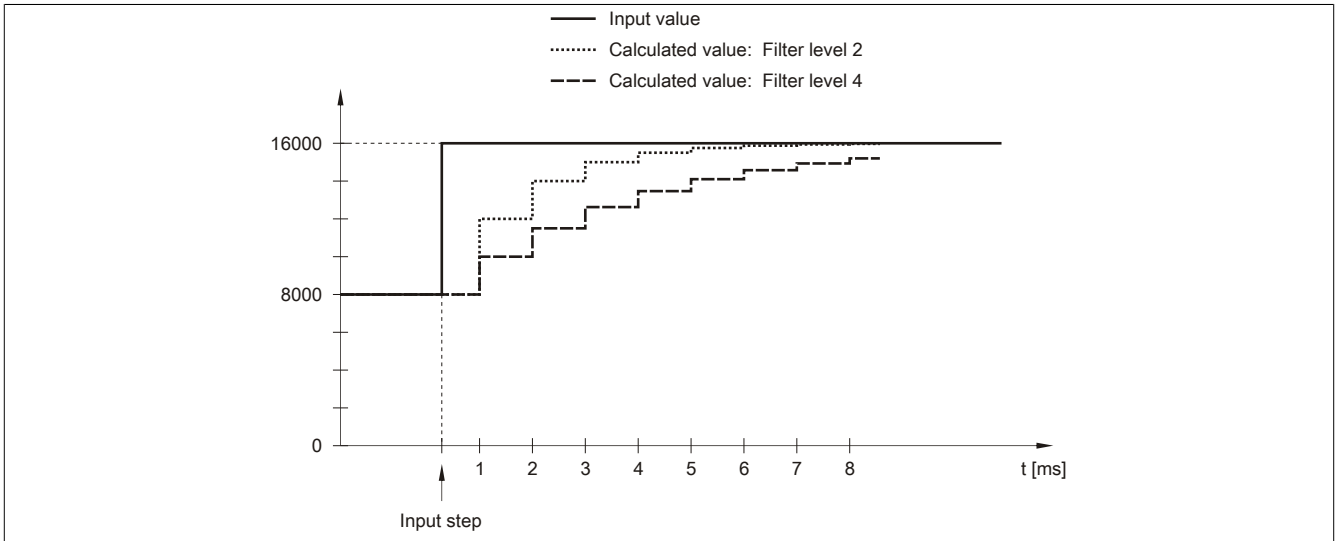

Figure 3: Calculated value during input step

### Example 2

A disturbance interferes with the input value. The diagram shows the calculated value with the following settings:

Input ramp limiting = 0

Filter level = 2 or 4

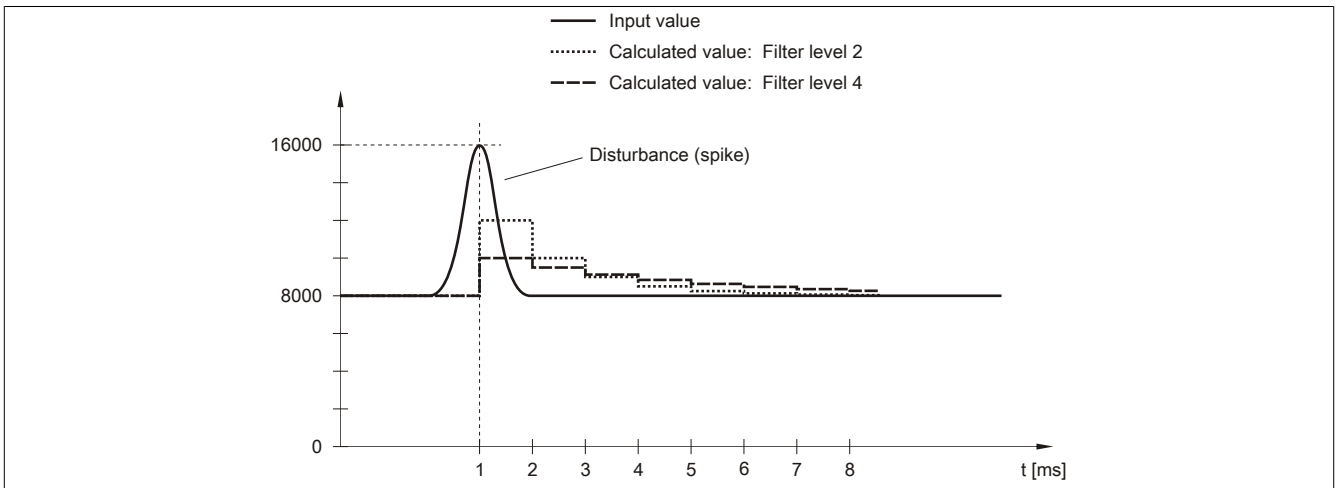

Figure 4: Calculated value during disturbance



## 9.7 Configuring the input filter

Name:

ConfigOutput01

The filter level and input ramp limiting of the input filter are set in this register.

Data type	Values	Bus controller default setting
USINT	See the bit structure.	0

Bit structure:

Bit	Description	Value	Information
0 - 2	Defines the filter level	000	Filter disabled (bus controller default setting)
		001	Filter level 2
		010	Filter level 4
		011	Filter level 8
		100	Filter level 16
		101	Filter level 32
		110	Filter level 64
		111	Filter level 128
3	Reserved	0	
4 - 6	Defines input ramp limiting	000	The input value is applied without limitation (bus controller default setting)
		001	Limit value = 0x3FFF (16383)
		010	Limit value = 0x1FFF (8191)
		011	Limit value = 0x0FFF (4095)
		100	Limit value = 0x07FF (2047)
		101	Limit value = 0x03FF (1023)
		110	Limit value = 0x01FF (511)
		111	Limit value = 0x00FF (255)
7	Reserved	0	

## 9.8 Channel type

Name:

ConfigOutput02

The type and range of signal measurement can be set in this register.

The individual channels are designed for current and voltage signals. This differentiation is made using different terminals and an integrated switch in the module. The switch is automatically activated by the module depending on the specified configuration. The following input signals can be set:

- $\pm 10$  V voltage signal (default)
- 0 to 20 mA current signal
- 4 to 20 mA current signal

Data type	Values	Bus controller default setting
USINT	See the bit structure.	0

Bit structure:

Bit	Description	Value	Information
0	Channel 1	0	Voltage signal (bus controller default setting)
		1	Current signal, measurement range corresponding to bit 4
...		...	
3	Channel 4	0	Voltage signal (bus controller default setting)
		1	Current signal, measurement range corresponding to bit 7
4	Channel 1: Current measurement range	0	0 to 20 mA current signal (bus controller default setting)
		1	4 to 20 mA current signal
...		...	
7	Channel 4: Current measurement range	0	0 to 20 mA current signal (bus controller default setting)
		1	4 to 20 mA current signal

## 9.9 Limit values

The input signal is monitored at the upper and lower limit values. These must be defined according to the operating mode:

Limit value (default)	Voltage signal $\pm 10$ V		Current signal 0 to 20 mA		Current signal 4 to 20 mA	
Upper maximum limit value	+10 V	+32767 (0x7FFF)	20 mA	+32767 (0x7FFF)	20 mA	+32767 (0x7FFF)
Lower minimum limit value	-10 V	-32767 (0x8001)	0 mA	0 <sup>1)</sup>	4 mA	0 <sup>2)</sup>

1) The analog value is limited down to 0.

2) The analog value is limited down to 0 at currents <4 mA. The status bit for the lower limit is set.

Other limit values can be defined if necessary. The limit values apply to all channels. These are enabled automatically by writing to the limit value registers. From this point on, the analog values will be monitored and limited according to the new limits. The results of monitoring are displayed in the status register.

### Examples of limit value settings

Use case	Limit value settings
Current signal: 4 to 20 mA	If values <4 mA should be measured for a current signal with 4 to 20 mA, a negative limit value must be set: 0 mA corresponds to value -8192 (0xE000).
Mixed voltage and current signal	The set limit values apply to all channels. A compromise must therefore be made for mixed operation (voltage and current signal mixed). The following setting has proven to be effective: Upper limit value = +32767, lower limit value = -32767 This also allows negative voltage values to be measured. With a lower limit value of 0, the voltage value would be limited to 0.
Current signal on all channels	All channels are configured for current measurement. The limit value setting in Automation Studio is not adjusted automatically. This means that +32767 is set for the upper limit value and -32767 for the lower limit value. The necessary adjustments must be made by the user, e.g. lower limit value = 0

#### 9.9.1 Lower limit value

Name:

ConfigOutput03

The lower limit value for analog values can be set in this register. If the analog value goes below the limit value, it is frozen at this value and the corresponding error status bit is set.

Data type	Values	Information
INT	-32768 to 32767	Bus controller default setting: -32768

#### Information:

- The default value of **-32767** corresponds to the minimum default value of **-10 VDC**.
- For a **0 to 20 mA** configuration, this value should be set to **0**.
- For a **4 to 20 mA** configuration, this value can be set to **-8192** (corresponds to **0 mA**) in order to display values <4 mA.

#### Information:

It is important to note that this setting applies to all channels!

#### 9.9.2 Upper limit value

Name:

ConfigOutput04

The upper limit value for analog values can be set in this register. If the analog value goes above the limit value, it is frozen at this value and the corresponding error status bit is set.

Data type	Values	Information
INT	-32767 to 32767	Bus controller default setting: 32767

#### Information:

The default value **32767** corresponds to the maximum default value at **20 mA** or **+10 VDC**.

#### Information:

It is important to note that this setting applies to all channels!

## 9.10 Status of the inputs

Name:  
StatusInput01

The module inputs are monitored in this register. A change in the monitoring status is actively transmitted as an error message. The following states are monitored depending on the settings:

Value	Voltage signal $\pm 10$ V	Current signal 0 to 20 mA	Current signal 4 to 20 mA
0	No error	No error	No error
1	Lower limit value undershot	Default setting The input value has a lower limit of 0x0000. Underflow monitoring is therefore not necessary. After lower limit value change The input value is limited to the configured value. The status bit is set when the value falls below the lower limit.	Lower limit value undershot
2	Upper limit value overshoot	Upper limit value overshoot	Upper limit value overshoot
3	Open circuit	-	-

Data type	Values
USINT	See the bit structure.

Bit structure:

Bit	Description	Value	Information
0 - 1	Channel 1	00	No error
		01	Lower limit value undershot
		10	Upper limit value overshoot
		11	Open circuit
...		...	
6 - 7	Channel 4	00	No error
		01	Lower limit value undershot
		10	Upper limit value overshoot
		11	Open circuit

### Limiting the analog value

In addition to the status information, the analog value is fixed to the values listed below by default in an error state. The analog value is limited to the new values if the limit values were changed.

Error state	Digital value on error (default values)
Open circuit	+32767 (0x7FFF)
Upper limit value overshoot	+32767 (0x7FFF)
Lower limit value undershot	-32767 (0x8001)
Invalid value	-32768 (0x8000)

## 9.11 Minimum cycle time

The minimum cycle time specifies the time up to which the bus cycle can be reduced without communication errors occurring. It is important to note that very fast cycles reduce the idle time available for handling monitoring, diagnostics and acyclic commands.

Minimum cycle time	
Inputs without filtering	100 $\mu$ s
Inputs with filtering	500 $\mu$ s

## 9.12 Minimum I/O update time

The minimum I/O update time specifies how far the bus cycle can be reduced so that an I/O update is performed in each cycle.

Minimum I/O update time	
Inputs without filtering	300 $\mu$ s for all inputs
Inputs with filtering	1 ms