

# X20(c)DO4322

---

## 1 General information

The module is equipped with 4 outputs for 3-wire connections.

- 4 digital outputs
- Source connection
- 3-wire connections
- 24 VDC and GND for actuator supply
- Integrated output protection
- OSP mode

## 2 Coated modules

Coated modules are X20 modules with a protective coating for the electronics component. This coating protects X20c modules from condensation and corrosive gases.

The modules' electronics are fully compatible with the corresponding X20 modules.

**For simplification purposes, only images and module IDs of uncoated modules are used in this data sheet.**

The coating has been certified according to the following standards:

- Condensation: BMW GS 95011-4, 2x 1 cycle
- Corrosive gas: EN 60068-2-60, method 4, exposure 21 days



### 2.1 Starting temperature

The starting temperature describes the minimum permissible ambient temperature when the power is switched off at the time the coated module is switched on. This is permitted to be as low as  $-40^{\circ}\text{C}$ . During operation, the conditions as specified in the technical data continue to apply.

#### Information:

**It is important to absolutely ensure that there is no forced cooling by air currents in a closed control cabinet, for example using a fan or ventilation slots.**

### 3 Order data

Model number	Short description	Figure
	<b>Digital outputs</b>	
X20DO4322	X20 digital output module, 4 outputs, 24 VDC, 0.5 A, source, 3-wire connections	
X20cDO4322	X20 digital output module, coated, 4 outputs, 24 VDC, 0.5 A, source, 3-wire connections	
	<b>Required accessories</b>	
	<b>Bus modules</b>	
X20BM11	X20 bus module, 24 VDC keyed, internal I/O supply continuous	
X20BM15	X20 bus module, with node number switch, 24 VDC keyed, internal I/O supply continuous	
X20cBM11	X20 bus module, coated, 24 VDC keyed, internal I/O supply continuous	
	<b>Terminal blocks</b>	
X20TB12	X20 terminal block, 12-pin, 24 VDC keyed	

Table 1: X20DO4322, X20cDO4322 - Order data

### 4 Technical data

Model number	X20DO4322	X20cDO4322
<b>Short description</b>	4 digital outputs 24 VDC for 3-wire connections	
<b>General information</b>		
B&R ID code	0x1B97	0xE226
Status indicators	I/O function per channel, operating state, module status	
Diagnostics		
Module run/error	Yes, using status LED and software	
Outputs	Yes, using status LED and software (output error status)	
Power consumption		
Bus	0.16 W	
Internal I/O	0.49 W	
Additional power dissipation caused by actuators (resistive) [W] <sup>1)</sup>	+0.21	
Certifications		
CE	Yes	
ATEX	Zone 2, II 3G Ex nA nC IIA T5 Gc IP20, Ta (see X20 user's manual) FTZÚ 09 ATEX 0083X	
UL	cULus E115267 Industrial control equipment	
HazLoc	cCSAus 244665 Process control equipment for hazardous locations Class I, Division 2, Groups ABCD, T5	
DNV GL	Temperature: <b>B</b> (0 - 55°C) Humidity: <b>B</b> (up to 100%) Vibration: <b>B</b> (4 g) EMC: <b>B</b> (bridge and open deck)	
LR	ENV1	
KR	Yes	
EAC	Yes	
KC	Yes	-
<b>Digital outputs</b>		
Variant	FET positive switching	
Nominal voltage	24 VDC	
Switching voltage	24 VDC -15 % / +20 %	
Nominal output current	0.5 A	
Total nominal current	2 A	
Connection type	3-wire connections	
Output circuit	Source	
Output protection	Thermal cutoff if overcurrent or short circuit occurs (see value "Peak short circuit current") Internal inverse diode for switching inductive loads (see section "Switching inductive loads")	
Actuator power supply	0.5 A in total for output-independent actuator supply	
Diagnostic status	Output monitoring with 10 ms delay	
Leakage current when the power is switched off	5 µA	
R <sub>DS(on)</sub>	210 mΩ	
Peak short-circuit current	<12 A	
Switch-on in the event of overload shutdown or short-circuit shutdown	Approx. 10 ms (depends on the module temperature)	

Table 2: X20DO4322, X20cDO4322 - Technical data

Model number	X20DO4322	X20cDO4322
Switching delay <sup>2)</sup>		
0 → 1		<300 µs
1 → 0		<300 µs
Switching frequency		
Resistive load <sup>2)</sup>		Max. 500 Hz
Inductive load		See section "Switching inductive loads"
Braking voltage when switching off inductive loads		Typ. 50 VDC
Isolation voltage between channel and bus		500 V <sub>eff</sub>
<b>Actuator power supply</b>		
Voltage	Module supply minus voltage drop for short circuit protection	
Voltage drop for short-circuit protection at 500 mA	Max. 2 V	
Short-circuit proof	Yes	
Power consumption		
Actuator power supply	Max. 12 W <sup>3)</sup>	
<b>Electrical properties</b>		
Electrical isolation	Channel isolated from bus Channel not isolated from channel and I/O power supply	
<b>Operating conditions</b>		
Mounting orientation		
Horizontal	Yes	
Vertical	Yes	
Installation elevation above sea level		
0 to 2000 m	No limitations	
>2000 m	Reduction of ambient temperature by 0.5°C per 100 m	
Degree of protection per EN 60529	IP20	
<b>Ambient conditions</b>		
Temperature		
Operation		
Horizontal mounting orientation	-25 to 60°C	
Vertical mounting orientation	-25 to 50°C	
Derating	-	
Starting temperature	-	Yes, -40°C
Storage	-40 to 85°C	
Transport	-40 to 85°C	
Relative humidity		
Operation	5 to 95%, non-condensing	Up to 100%, condensing
Storage	5 to 95%, non-condensing	
Transport	5 to 95%, non-condensing	
<b>Mechanical properties</b>		
Note	Order 1x X20TB12 terminal block separately Order 1x X20BM11 bus module separately	Order 1x X20TB12 terminal block separately Order 1x X20cBM11 bus module separately
Pitch	12.5 <sup>+0.2</sup> mm	

Table 2: X20DO4322, X20cDO4322 - Technical data

- 1) Number of outputs x R<sub>DS(on)</sub> x Nominal output current<sup>2</sup>. For a calculation example, see section "Mechanical and electrical configuration" of the X20 system user's manual.
- 2) At loads ≤ 1 kΩ
- 3) The power consumption of the sensors connected to the module is not permitted to exceed 12 W.

## 5 Status LEDs

For a description of the various operating modes, see section "Additional information - Diagnostic LEDs" of the X20 system user's manual.

Figure	LED	Color	Status	Description	
	r	Green	Off	Module supply not connected	
			Single flash	RESET mode	
			Blinking	PREOPERATIONAL mode	
			On	RUN mode	
			Flickering (approx. 10 Hz)	The module is in the OSP state.	
	e	Red	Off	Module supply not connected or everything OK	
			Single flash	Warning/Error on an I/O channel. Level monitoring for digital outputs has been triggered.	
	e + r		Red on / Green single flash	Invalid firmware	
	1 - 4		Orange		Output status of the corresponding digital output

## 6 Pinout

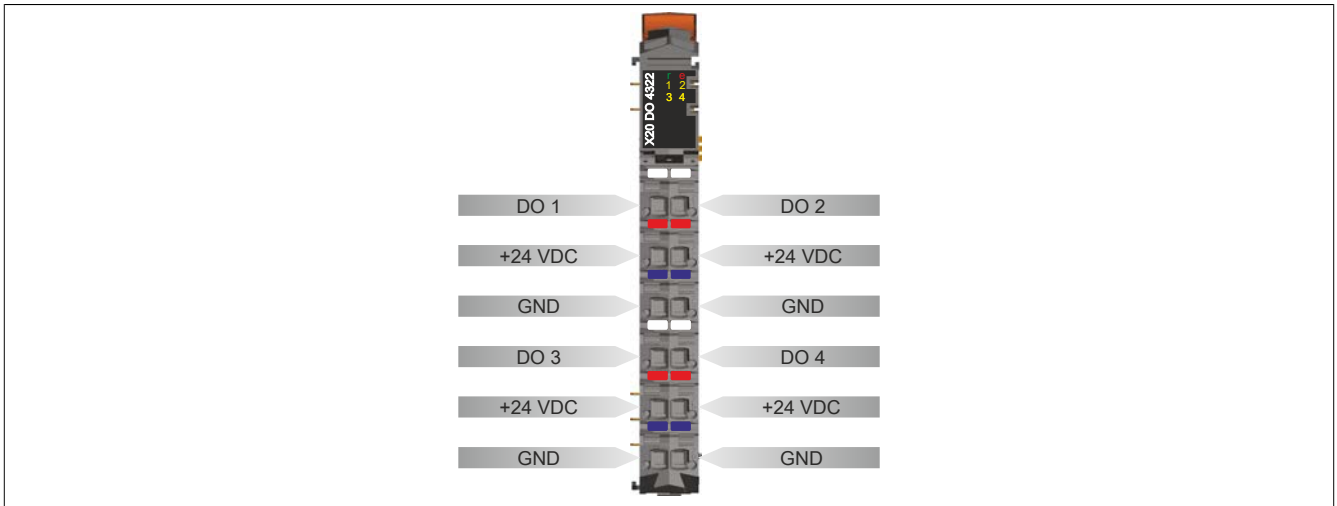

## 7 Connection example

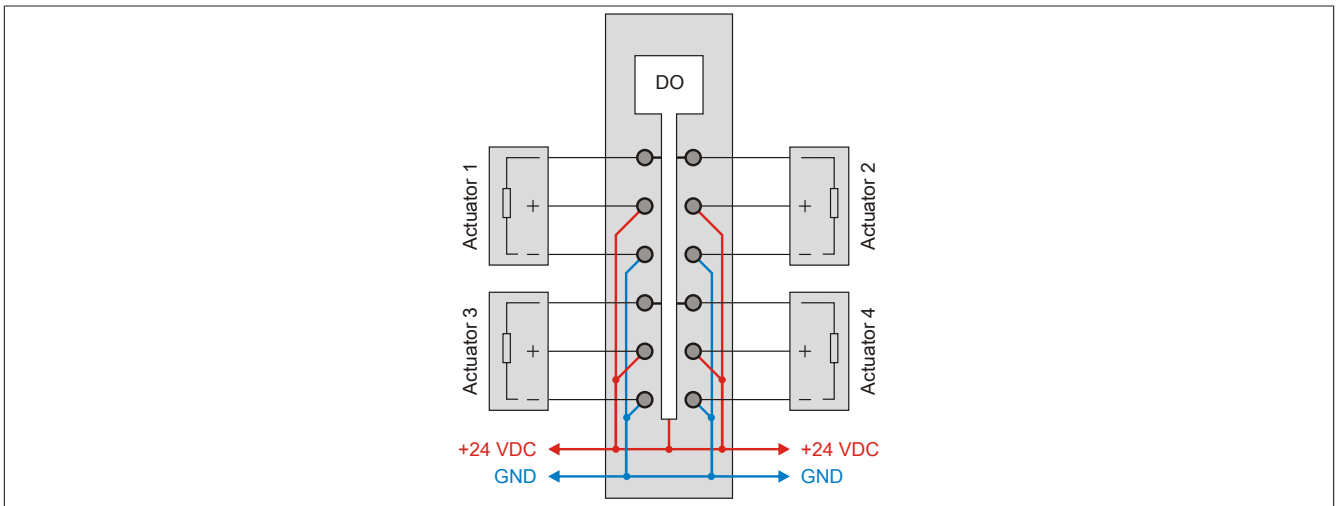

### Caution!

If the module is operated outside specifications, the output current may rise above the maximum permissible nominal current. This applies both to individual channels and to the summation current of the module.

Appropriate cable cross-sections or external safety measures must therefore be provided.

## 8 OSP hardware requirements

In order to use OSP mode sensibly, it should be ensured that the power supply of the output module and CPU are independent of each other when the application is set up.

## 9 Output circuit diagram

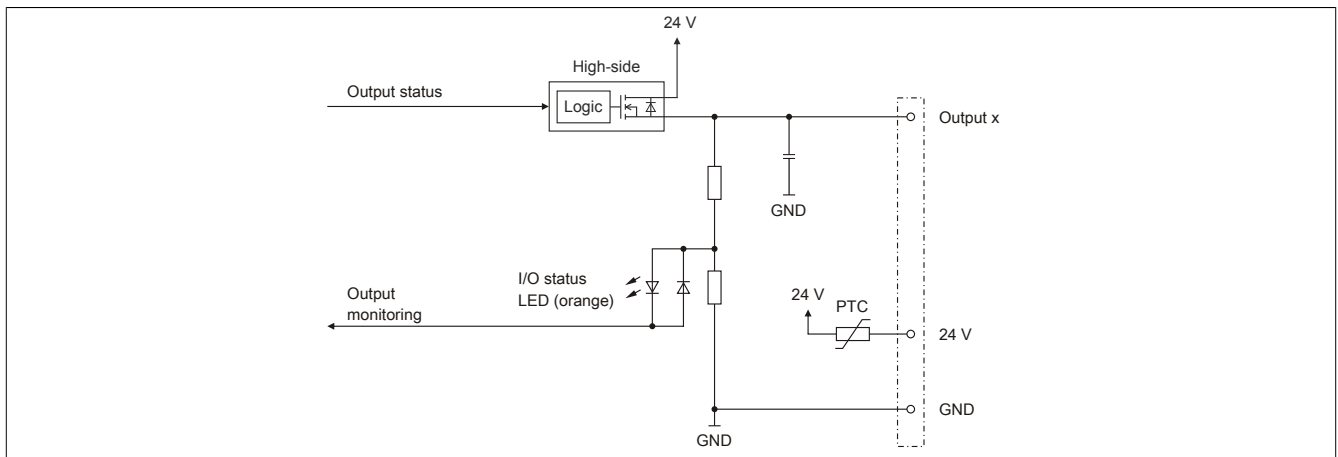

## 10 Switching inductive loads

Ambient temperature: 60°C, all outputs with the same load

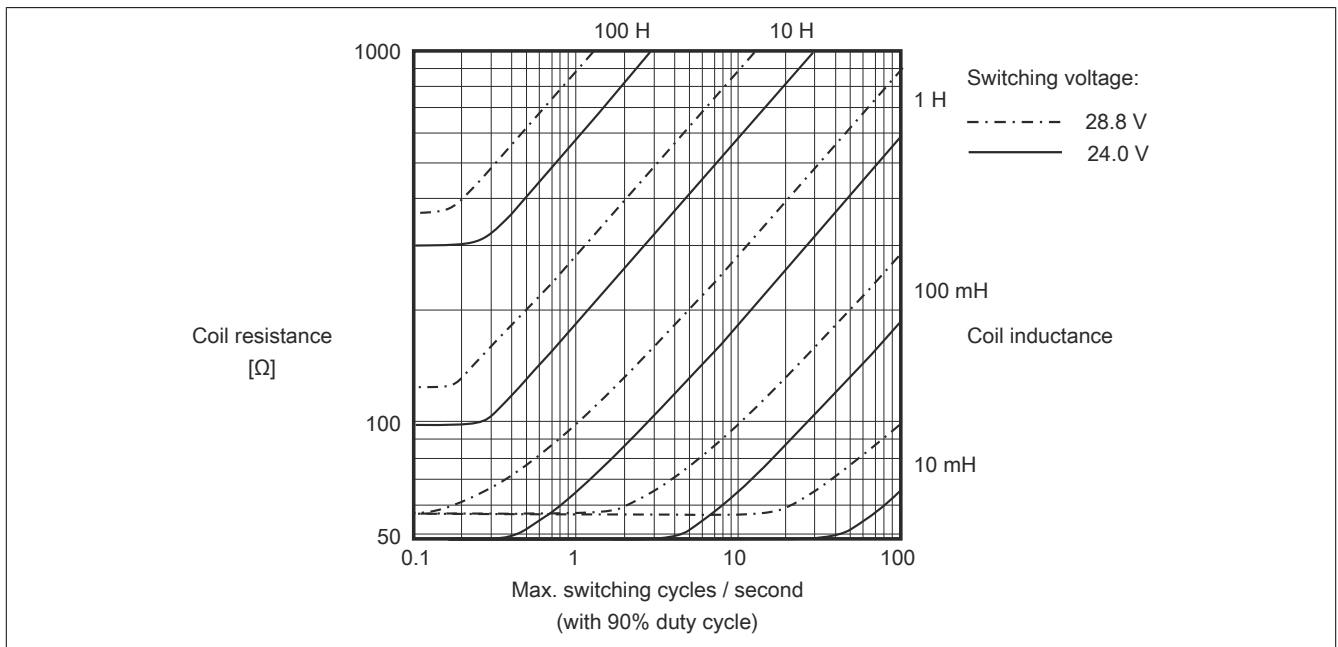

### Information:

If the maximum number of operating cycles per second is exceeded, an external inverse diode must be used.

Operating conditions outside of the area in the diagram are not permitted!

## 11 Register description

### 11.1 General data points

In addition to the registers described in the register description, the module has additional general data points. These are not module-specific but contain general information such as serial number and hardware variant.

General data points are described in section "Additional information - General data points" of the X20 system user's manual.

### 11.2 Function model 0 - Standard

Register	Fixed offset	Name	Data type	Read		Write	
				Cyclic	Acyclic	Cyclic	Acyclic
2	0	DigitalOutput	USINT			•	
		DigitalOutput01	Bit 0				
		...	...				
		DigitalOutput04	Bit 3				
30	1	StatusInput01	USINT	•			
		StatusDigitalOutput01	Bit 0				
		...	...				
		StatusDigitalOutput04	Bit 3				

Fixed modules require their data points to be in a specific order in the X2X frame. Cyclic access occurs according to a predefined offset, not based on the register address.

Acyclic access continues to be based on the register numbers.

### 11.3 Function model 1 - OSP

Register	Fixed offset	Name	Data type	Read		Write	
				Cyclic	Acyclic	Cyclic	Acyclic
2	0	Switching state of digital outputs 1 to 4	USINT			•	
		DigitalOutput01	Bit 0				
		...	...				
		DigitalOutput04	Bit 3				
30	1	Status of digital outputs 1 to 4	USINT	•			
		StatusDigitalOutput01	Bit 0				
		...	...				
		StatusDigitalOutput04	Bit 3				
34	1	Enabling OPS output in the module	USINT			•	
		OSPValid	Bit 0				
32	-	CfgOSPMODE	USINT				•
36	-	CfgOSPValue	USINT				•

Fixed modules require their data points to be in a specific order in the X2X frame. Cyclic access occurs according to a predefined offset, not based on the register address.

Acyclic access continues to be based on the register numbers.

### 11.4 Function model 254 - Bus Controller

Register	Offset <sup>1)</sup>	Name	Data type	Read		Write	
				Cyclic	Acyclic	Cyclic	Acyclic
2	0	Switching state of digital outputs 1 to 4	USINT			•	
		DigitalOutput01	Bit 0				
		...	...				
		DigitalOutput04	Bit 3				
30	-	Status of digital outputs 1 to 4	USINT		•		
		StatusDigitalOutput01	Bit 0				
		...	...				
		StatusDigitalOutput04	Bit 3				

1) The offset specifies where the register is within the CAN object.

#### 11.4.1 Using the module on the bus controller

Function model 254 "Bus controller" is used by default only by non-configurable bus controllers. All other bus controllers can use other registers and functions depending on the fieldbus used.

For detailed information, see section "Additional information - Using I/O modules on the bus controller" of the X20 user's manual (version 3.50 or later).

## 11.4.2 CAN I/O bus controller

The module occupies 1 digital logical slot on CAN I/O.

## 11.5 Digital outputs

The output state is transferred to the output channels with a fixed offset (<60 µs) based on the network cycle (SyncOut).

### 11.5.1 Switching state of digital outputs 1 to 4

Name:

DigitalOutput

DigitalOutput01 to DigitalOutput04

This register is used to store the switching state of digital outputs 1 to 4.

Only function model 0 - Standard:

Setting "Packed outputs" in the Automation Studio I/O configuration determines whether all bits of this register should be applied individually as data points in the Automation Studio I/O assignment ("DigitalOutput01" to "DigitalOutput0x") or whether this register should be displayed as a single USINT data point ("DigitalOutput").

Data type	Values	Information
USINT	0 to 15	Packed outputs = On
	See the bit structure.	Packed outputs = Off or function model ≠ 0 - Standard.

Bit structure:

Bit	Description	Value	Information
0	DigitalOutput01	0	Digital output 01 reset
		1	Digital output 01 set
...		...	
3	DigitalOutput04	0	Digital output 04 reset
		1	Digital output 04 set

## 11.6 Monitoring status of the digital outputs

On the module, the output states of the outputs are compared to the target states. The control of the output driver is used for the target state.

A change in the output state resets monitoring for that output. The status of each individual channel can be read. A change in the monitoring status is actively transmitted as an error message.

### 11.6.1 Status of digital outputs 1 to 4

Name:

StatusInput01

StatusDigitalOutput01 to StatusDigitalOutput04

This register contains the state of digital outputs 1 to 4.

Only function model 0 - Standard:

Setting "Packed outputs" in the Automation Studio I/O configuration determines whether all bits of this register should be applied individually as data points in the Automation Studio I/O assignment ("StatusDigitalOutput01" to "StatusDigitalOutput0x") or whether this register should be displayed as a single USINT data point ("StatusInput01").

Data type	Values	Information
USINT	0 to 15	Packed outputs = On
	See the bit structure.	Packed outputs = Off or function model ≠ 0 - Standard.

Bit structure:

Bit	Description	Value	Information
0	StatusDigitalOutput01	0	Channel 01: No error
		1	Channel 01: <ul style="list-style-type: none"> <li>Short circuit or overload</li> <li>Channel switched on and missing I/O power supply</li> <li>Channel switched off and external voltage applied on channel</li> </ul>
...		...	
3	StatusDigitalOutput04	0	Channel 04: No error
		1	Channel 04: For an error description, see channel 01.

## 11.7 Function model "OSP"

In function model "OSP" (Operator Set Predefined), the user defines an analog value or digital pattern. This OSP value is output as soon as the communication between the module and master is aborted.

### Functionality

The user has the choice between 2 OSP modes:

- Retain last valid value
- Replace with static value

In the first case, the module retains the last value recognized as a valid output status.

When selecting mode "Replace with static value", a plausible output value must be entered in the associated value register. When an OSP event occurs, this value is output instead of the value currently requested by the task.

#### 11.7.1 Enabling OPS output in the module

Name:  
OSPValid

This data point makes it possible to start the output of the module and request the use of OSP during operation.

Data type	Values
USINT	See the bit structure.

Bit structure:

Bit	Description	Value	Information
0	OSPValid	0	Request OSP operation (after initial startup or module in stand-by)
		1	Request normal operation
1 - 7	Reserved	0	

Bit OSPValid exists once on the module and is managed by the user task. It must be set to start the enabled channels. As long as bit OSPValid remains set in the module, the module behaves the same as in function model "Standard".

If an OSP event occurs, e.g. communication between the module and master CPU aborted, then bit OSPValid is reset on the module. The module enters the OSP state and output occurs according to the configuration in register "OSPMode" on page 9.

#### The following generally applies:

**Even after regeneration of the communication channel, the OSP replacement value is still pending. The OSP state is only exited again when a set OSPValid bit is transferred.**

**When the master CPU is restarted, bit OSPValid bit is reinitialized in the master CPU. It must be set once more by the application and transferred via the bus.**

**In the event of brief communication errors between the module and master CPU (e.g. due to EMC), the cyclic registers fail to refresh for several bus cycles. Within the module, bit OSPValid is reset; the set bit is retained in the CPU, however. During the next successful transfer, the module-internal OSPValid bit is set again and the module automatically returns to normal operation.**

If the task in the master CPU needs the information about which output mode the module is currently in, bit ModulOK can be evaluated.

### Warning!

**If bit OSPValid bit is reset to "0" by the module, the output status no longer depends on the responsible task in the master CPU. Nevertheless, output is made depending on the configuration of the OSP replacement value.**



### 11.7.2 Setting OSP mode

Name:  
CfgOSPMode

This register controls the behavior of a channel when using OSP.

Data type	Values	Explanation
USINT	0	Replace with static value
	1	Retain last valid value

### 11.7.3 Defining an OSP-digital output value

Name:  
CfgOSPValue

This register contains the digital output value that is output in "Replace with static value" mode during OSP operation.

Data type	Values
USINT	See the bit structure.

Bit structure:

Bit	Description	Value	Information
0		0 or 1	OSP output value for channel DigitalOutput00
...		...	
x		0 or 1	OSP output value for channel DigitalOutput0x

## Warning!

"OSPValue" is only applied by the module if bit "OSPValid" has been set in the module.

### 11.8 Minimum cycle time

The minimum cycle time specifies the time up to which the bus cycle can be reduced without communication errors occurring. It is important to note that very fast cycles reduce the idle time available for handling monitoring, diagnostics and acyclic commands.

Minimum cycle time
100 $\mu$ s

### 11.9 Minimum I/O update time

The minimum I/O update time specifies how far the bus cycle can be reduced so that an I/O update is performed in each cycle.

Minimum I/O update time
Equal to the minimum cycle time